

# **Pre-Installation Guide For Quasar Laser Systems**

Spectra-Physics  
3635 Peterson Way  
Santa Clara, CA 95054  
800- 456-2552  
March 2020

## Table of Contents

Introduction.....	3
When Your System Arrives.....	4
Pre-Installation Considerations.....	5
Environmental Specifications.....	5
Utility Requirements.....	5
Utility Requirements (Cont'd).....	6
Outline Drawings.....	7
Laser Head.....	7
Outline Drawings (Cont'd).....	8
Laser Head (Cont'd).....	8
Outline Drawings (Cont'd).....	9
Power Supply.....	9
Outline Drawings (Cont'd).....	10
Chiller Drawings.....	10
Heat Dissipation Requirements.....	11
Air Flow Requirements.....	11
Computer Requirements.....	12
Interface Requirements.....	12
Computer Requirements (Cont'd).....	13
Baud Rate Default.....	14
Inspecting and Unpacking.....	14
Accessory Kit Parts List.....	15
Tooling Requirements.....	15
Lifting and Moving the Laser.....	16
Unpacking the Laser System.....	17
Unpacking the Power Supply/Accessory Kit Crate.....	17
Unpacking the Power Supply/Accessory Kit Crate (Cont'd).....	18
Unpacking the Power Supply.....	19
Unpacking the Power Supply (Cont'd).....	20
Unpacking the Laser Head.....	21
Unpacking the Laser Head (Cont'd).....	22
Unpacking the Laser Head (Cont'd).....	23
Unpacking the Optional Chiller.....	24
Packing the Laser System for Transportation or Return to Spectra-Physics.....	25
Indexing and Multiple Mounting Schemes.....	25
Primary (Recommended) Installation Options for Bench Testing.....	25
Additional Installation Options.....	26
Possible Minor Modification (can easily be implemented).....	26
Mounting Requirements for the Power Supply.....	26
Installation Requirements for the Chiller.....	27
General Information.....	27
Interconnect Diagram.....	28
Required Maintenance:.....	29

## Introduction

Congratulations on your purchase of a Spectra-Physics laser system. The purpose of this document is to assist the user in establishing a suitable location and operating environment for optimum performance of the Quasar system.

Proper power and room temperatures are required for each system. You are responsible for meeting these requirements prior to installation, with due consideration given to all applicable building and safety codes.

## When Your System Arrives

When the system arrives inspect the shipping containers for signs of rough handling or damage. Indicate any such signs on the bill of lading. Report any damage immediately to the shipping carrier and to a Spectra-Physics Customer Service Representative.

Retain the shipping containers. The containers will be required if the system is returned to the factory for service. The containers may also be needed to support a shipping damage claim.

The packing list identifies all items that have been ordered. Check each item received against the packing list, open all packages and inspect them for possible shipping damage. Make sure that each system has a user's Packet, which contains a USB stick. Note that some items may have been installed at the factory. Report any missing or damaged items to Spectra-Physics.

## Pre-Installation Considerations

### Environmental Specifications

The environmental conditions under which the laser system functions are listed on Spectra-Physics website at <http://www.newport.com/Quasar>

These specifications reflect indoor use conditions.

Feature	Specifications
Altitude	Up to 3000M
Temperatures	15C to 35C
Maximum relative humidity	85% non-condensing for temperatures up to 31C
Mains Supply Voltage	Do not exceed + 10% of the nominal voltage
Insulation category	II
Pollution degree	2

### Utility Requirements

Provide enough room cooling capacity to remove this waste heat and prevent the system from overheating. Provide at least 6 inches of unobstructed space around the front and 8 inches at the rear panels of the QPS to allow cooling air to enter the front and heated air to exhaust from the back. The power supply draws 200 CFM of air flow.

Feature	Specifications
AC Power input	190 to 240 VAC (15 Amp service)
Maximum power consumption (EOL)	2200W

The Quasar Laser will NOT operate on 110VAC

The circuit must be capable of delivering 15 Amps. You must use two separate 15 Amp circuits for the chiller and controller.

The QPS power supply incorporates double-pole neutral fusing for operation from 190 to 240 VAC. These two fuses are located on the rear panel of the power supply and can be accessed using a standard screwdriver. Replacement fuses must be size 5 x 32 mm and of same type and rating as below.

Supply Voltage	Fuse (x2, ceramic package)
190 – 240 VAC	T15 A/250 slow blow

## Utility Requirements (Cont'd)

The Quasar laser head is water-cooled and does not require any other sort of cooling. The system must be installed in a stable environment. The controller is force-air-cooled with a maximum output power of ~ 300 Watts. The controller requires approximately 200 CFM of free-air-flow. The air-flow direction is front-to-back (warm air exhausts out the rear of the controller).

### Chiller

<b>Feature</b>	<b>Specifications</b>
Fluid temperature	20°C +/-0.5
Fluid flow rate	9.5 liter/min @ 210 kPa (2.5 Gpm @ 30 psi at laser head inlet)

### Hose and Cable Lengths

There is a 2.5 m (8 ft.) 3-wire AC power cord, no plug (the customer must provide and install the plug for this power cord).

The LASER HEAD control cable is a standard 5 m (16 ft.).

The SHUTTER control cable is a standard 5 m (16 ft.).

The air hoses with connectors are a standard 5 m (16 ft.).

## Outline Drawings

### Laser Head

All dimensions in the figures are inches over mm.

Note

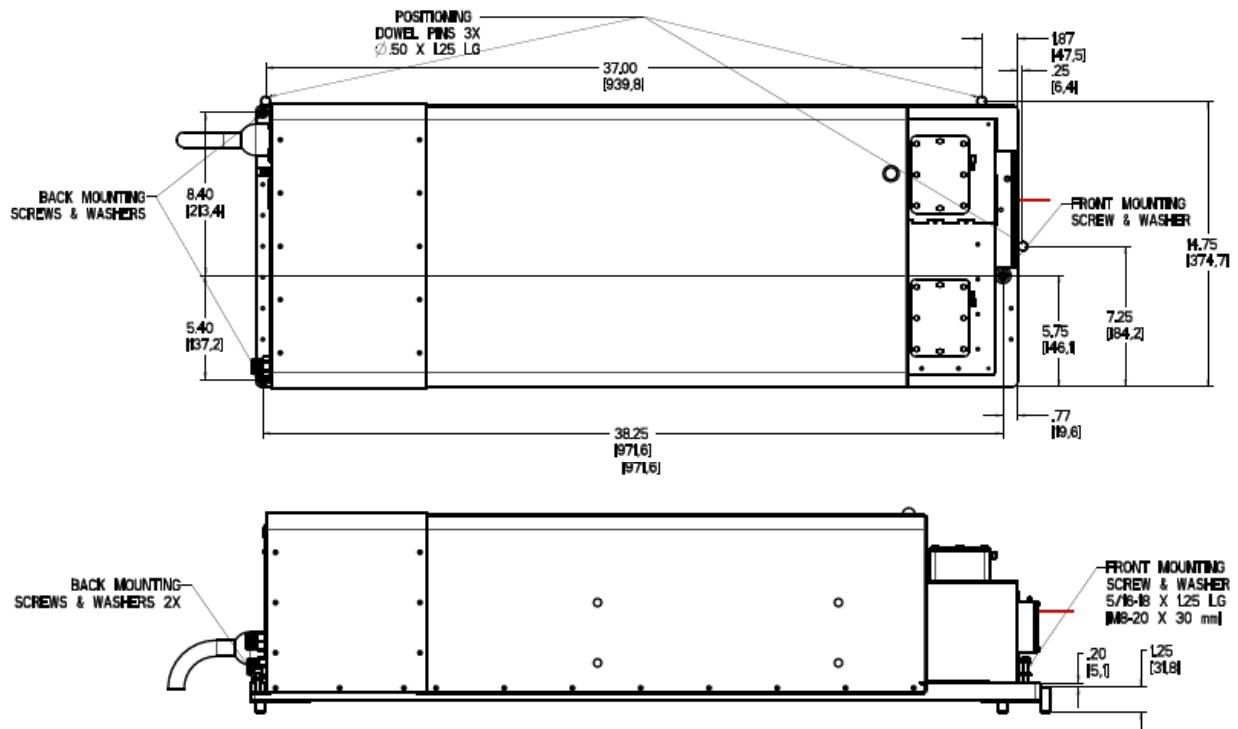

Figure 1-1 Quasar laser head outline, top and side view

Outline Drawings (Cont'd)

Laser Head (Cont'd)

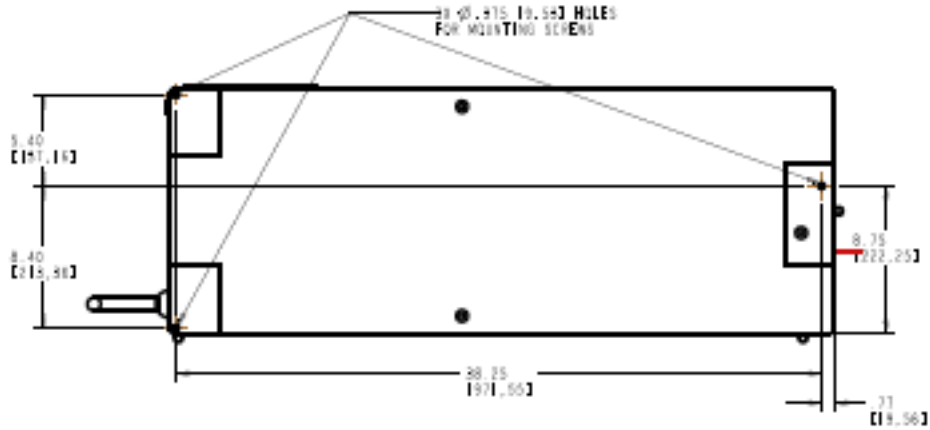

Figure 1-2 Quasar laser head outline, bottom view

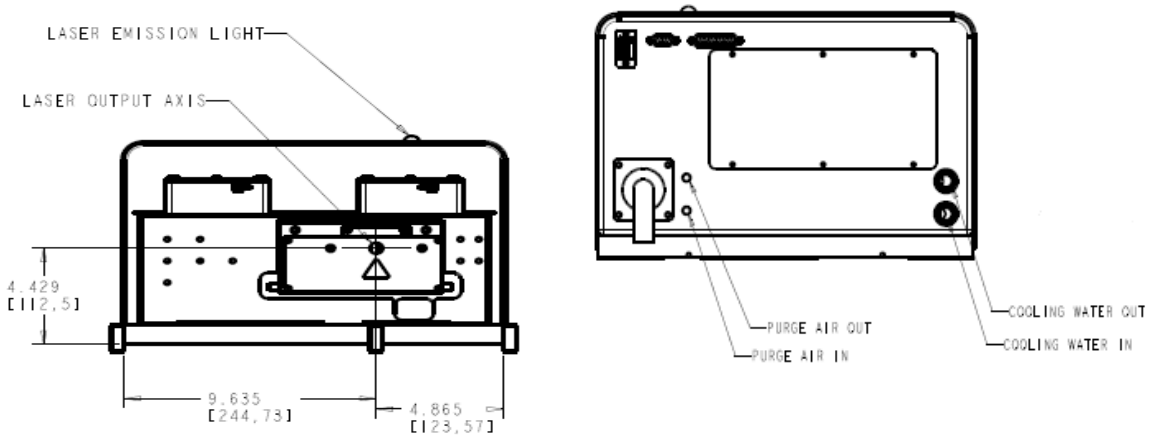

Figure 1-3 Quasar laser head outline, front (left) and rear (right) view



## Outline Drawings (Cont'd)

### Power Supply

Note



All dimensions in the figures are inches over mm

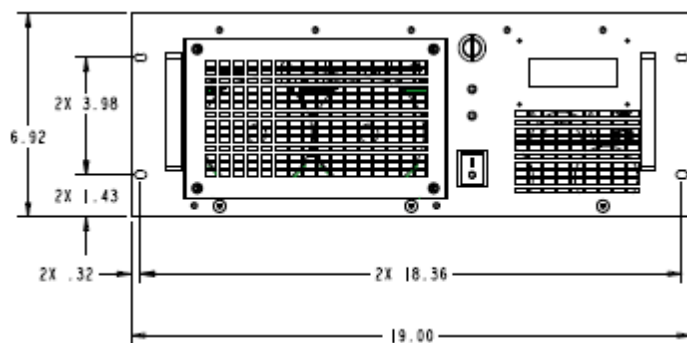

Figure 1-5 QPS power supply outline, front

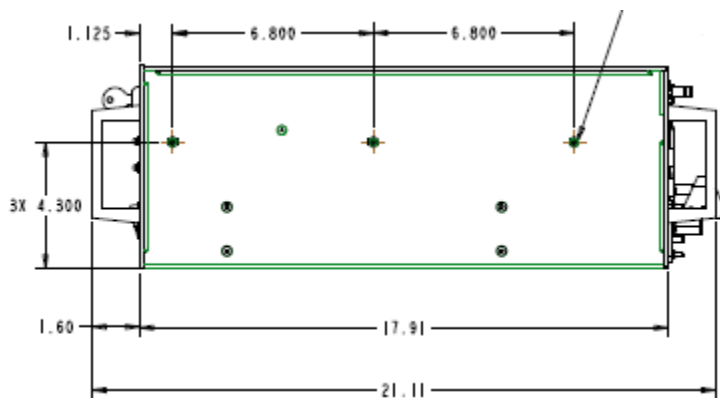
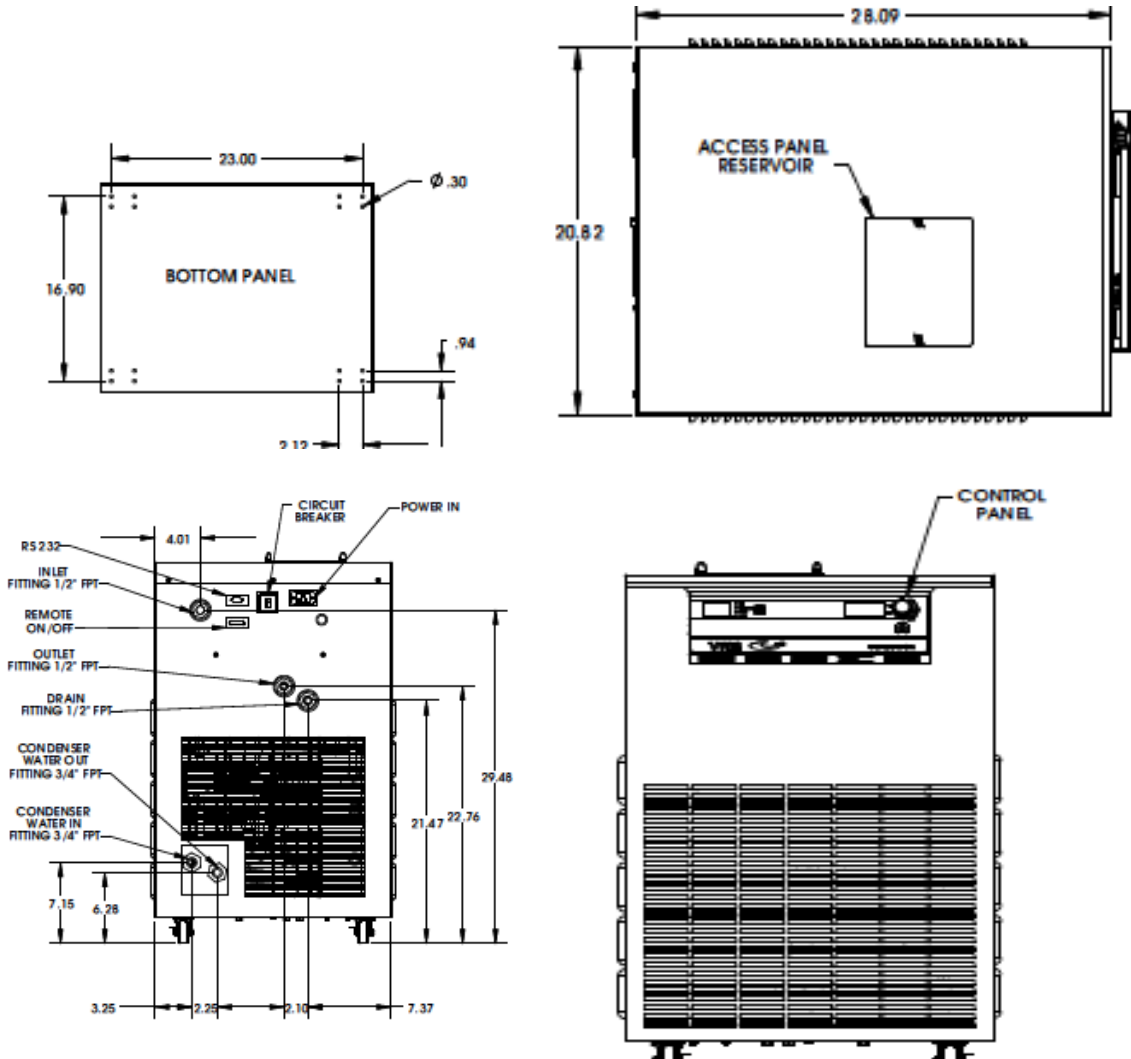

Figure 1-6 QPS power supply outline, side

## Outline Drawings (Cont'd)

### Chiller Drawings



## Heat Dissipation Requirements

The power supply dissipates approximately 300 watts

## Air Flow Requirements

### **Laser**

Self-contained purge system (ALPS) and does not require filters.

### **Power Supply**

Provide enough room cooling capacity to remove this waste heat and prevent the system from overheating.

Provide at least 15 cm (8 in.) of unobstructed space around the front and rear panels of the QPS to allow cooling air to enter the front and heated air to exhaust from the back.

The power supply draws 200 CFM of air flow.

You must leave 8 inches of clearance behind the QPS for airflow and umbilical attachment and bend radius. If QPS is rack mounted make sure to leave enough space for a service loop on cables and connections.

### **Chiller**

The chiller selected must be able to dissipate 2200 watts and maintain a regulated coolant temperature of 20C  $\pm$ .5C, under all operating conditions for ambient temperature, humidity, and altitude at the end of life of the laser.

### **Nalco**

Nalco 460-PCCL104 is a premixed, liquid corrosion inhibitor that can be added directly to a closed-loop cooling system. It is designed to protect ferrous metals and copper alloys from corrosion. It is nitrite free and it minimizes the problems associated with bacteria control. Nalco can be ordered directly from Spectra-Physics, P/N 1607-0546.

See Appendix B, “Nalco MSDS,” in the User’s Manuel for more information about the Nalco product.

## Computer Requirements

- 1) OS:
  - a. Windows XP with Service Pack 3
  - b. Windows Vista
  - c. Windows 7.
  - d. Not tested with Windows 8 yet.
- 2) RAM: 2 GB (1GB is probably fine)
- 3) Free Disk Space: 1 GB
- 4) USB or RS232 Port.
- 5) Optional: Ethernet Port that set to static IP Mode (Recommended IP Address: 192.168.0.10) for log reading.

## Interface Requirements

The *Quasar* system can be controlled using the provided GUI, or signals applied to the LASER CONTROL interface, or by a combination of serial commands and analog signals provided by a host system.

You can use the following methods to control the *Quasar* system:

- Serial commands or GUI commands, which are convenient
- Analog signals through the BNC connectors
- Analog signals through the opto-isolated interface is fast, but requires circuitry for the opto-isolated connections
- A combination of serial commands, and BNC inputs or analog signals

The combination of the flexibility of serial commands with the speed of BNC or analog signals provide maximum control of the system. For manual operation, enter serial commands using the *Quasar* GUI or a terminal emulator such as *HyperTerminal*.

USB connector    Used in conjunction with the LASER CONTROL port to control the laser system.

Alternatively, the SERIAL COM port (see below) can be used instead. Refer to Appendix A, “Serial Command Interface,” in the User Manual for instructions on how to control the laser using the serial command language. Connect your control device (e.g., a computer) to this type-B connector using a standard USB cable. The USB port is the recommended means of providing serial control.

## Computer Requirements (Cont'd)

Ethernet            Quasar is configured with static IP address and supports terminal operation via TCP/IP. refer to instructions for your laptop on configuring this interface: (Turning the key switch to the off position will reveal the IP address on the LCD.)

Static IP: 193.168.0.50  
Port: 3000

SERIAL COM connector (9-pin, D-sub, male)

Used in conjunction with the LASER CONTROL input to control the laser system. Alternatively, the USB port (see below) can be used instead. Refer to Appendix A, "Serial Command Interface," for instructions on controlling the laser using the serial command language. The USB port is the recommended means of providing serial control. Use a standard 9-pin serial cable (M/F) to connect your control device (e.g., a computer) to this RS-232 serial connector. Only three of the nine pins are used. Refer to the pin descriptions in Table 1-5.

*Table 1-5 IBM/PMAT Serial*

RS-232-C -Signal Name	Computer or Terminal		QPS	
	Signal	Pin No. (9-Pin)	Pin No.	Signal
Transmit data	TXD	3	3	RXD
Receive data	RXD	2	2	TXD
Signal ground		5	5	
Protective ground		SHELL	SHELL	

## Baud Rate Default

The default baud rate is 19200. The GUI auto detects the rate, and will not run at any lower than 19200.

If you are having problems communicating with the laser, check the baud rate by turning the front panel key switch. The system shows where the baud rate is currently set.

## Inspecting and Unpacking

### Before You Begin

Before unpacking, setting up, or operating the *Quasar* laser or any of its components, review the safety information in Chapter 2, “Laser Safety and Compliance.”

### Inspecting the Shipment

Your *Quasar* laser was packed with great care and its container was inspected prior to shipment—it left Spectra-Physics in good condition. Upon receiving your system, immediately inspect the outside of the shipping container. If there is any major damage (holes in the container, crushing, etc.), insist that a representative of the carrier be present when you unpack the contents.

The three components of the *Quasar* system—the *Quasar* laser head, the *Quasar* power supply (*QPS*), and the optional chiller—are shipped in separate crates.

The system is delivered in two crates (three if a chiller is ordered). Ensure you have enough space in a clean environment to unpack the laser. Save all packaging material so if it becomes necessary to return the laser it can be shipped in the proper containers.

### System Components

- Crate 1: Power supply and accessory kit; includes all cables, power cords, keys, interlocks, and any optional items like hoses and fittings
- Crate 2: Chiller (optional); includes Nalco, hoses, and AC power cords
- Crate 3: Laser head

**NOTE:** *The standard shipping configuration is with the exoskeleton installed. If lifting handles are ordered they are mounted to the laser for shipment. If the optional shutter is ordered it is also installed on the laser.*

**NOTE:** *If the optional chiller is **not** ordered, and hoses are ordered they will be packaged with the *Quasar* Power Supply.*

## Accessory Kit Parts List

This manual, a packing slip listing all the parts shipped, and an accessory kit containing the items listed below is shipped along with the laser system. Verify that all items are present. (Spectra-Physics part numbers are listed in Chapter 11, “Field Replaceable Units (FRUs)”)

- (1) 2.5 m (8 ft.) 3-wire AC power cord, no plug (the customer must provide and install the plug for this power cord)
  - (1) European (German) power cord
  - (1) 5 m (16 ft.) LASER HEAD control cable, standard
  - (1) 5 m (16 ft.) SHUTTER control cable, optional
  - (1) Power supply parts kit (INTERLOCK jumper plug, LASER CONTROL jumper plug, two keys, connector locks for AC connector, fuses (15 A, 250 V, slow-blow))
  - (2) 5 m (16 ft.) air hoses with connectors, standard
  - (1) USB memory stick containing the *Quasar* GUI software
  - (1) 3 m (10 ft.) Type A/B USB cable
  - (1) 5m (16 ft) Type A/A USB cable
- Optional Chiller:

- 1) AC 3-wire power cord, no plug (the customer must provide and install the plug for this power cord)
- 2) particle filter for the chiller (ships with chiller)
- 3) 5 m (16 ft.) water hoses with connectors, standard

## Tooling Requirements

An adjustable wrench to remove the (4) 5/16” bolts

A 5/32” hex ball driver (length ~ 10”)

A hoist with load capacity of 181 kg (400 lb.) to move the laser from the crate onto the table where it will operate

## Lifting and Moving the Laser

Spectra-Physics has specifically designed two service handles (ordered separately) to assist in moving the laser. Ensure that all the hardware is tight before moving the laser. Four people are required to move the laser if the lifting handles are going to be used.

***Use caution when lifting and moving laser. The laser head weighs 86 kg (190 lb.). The QPS weighs 16 kg (35.27 lb.).***

***The table or transportation cart onto which the laser will be placed must be capable of supporting at least 181 kg (400 lb.).***

***Best laser pointing is achieved if the mounting surface material is aluminum.***

***Dropping the laser (even from a small height) damages the laser and VOIDS your warranty.***

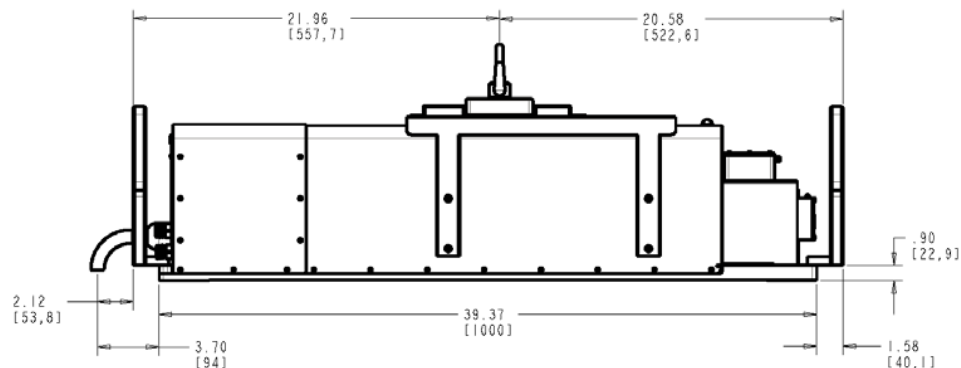
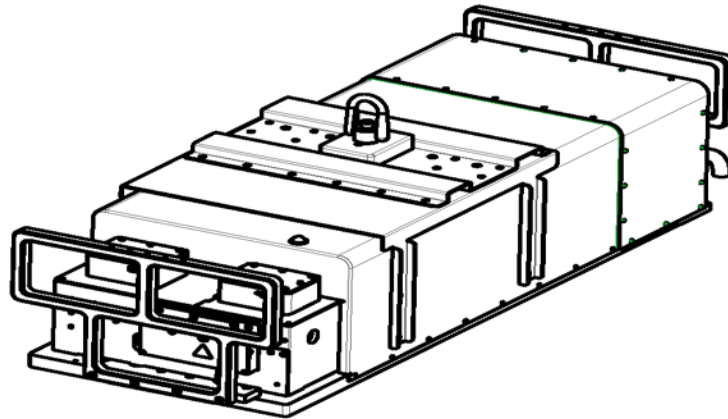

***The handles can be used to add safety straps to any lifting mechanism. The center of gravity is located at the eye bolt. As the laser is lifted, maintain the center of gravity. Reposition the bolt as needed.***



## Unpacking the Laser System

For customers who integrate the laser into a tool, Spectra-Physics recommends that the laser be shipped in its original container. The shipping crate offers the best protection. Spectra-Physics further recommends that you repackage the laser and vacuum seal the laser in a new shipping bag. You can find the laser head shipping kit in the FRU list.

**Keep all shipping materials.** *If you file a damage claim, you might need them to demonstrate that the damage occurred as a result of shipping. If you need to return the system for service at a later date, the specially designed container ensures adequate protection.*

*Note that the Quasar laser head weighs 86 kg (190 lb.) and the QPS weighs 16kg (35.27 lb.). **Four people** are required to move the laser head safely.*

## Unpacking the Power Supply/Accessory Kit Crate

*Verify that the tilt and shock watches (see Figure 4-3) on each crate are not tripped, indicating that the units were safely shipped. If they are tripped, carefully document any damage caused by the carrier.*

*The shock watches are on the sides of each crate. If the indicator on either watch shows that the crate has sustained possible damage, follow the instructions printed on the label, and notify the carrier and your Spectra-Physics representative. If they are not tripped, proceed with the next step.*



*Open the shipping crate and remove the power supply and accessory kit boxes.*

- a) *Using metal cutters, cut the shipping band.*
- b) *Unfasten the four clamps around the bottom of the crate that fasten the top portion of the crate (the cover) to the palette. Turn the handles counter-clockwise and disengage the latch as shown.*

## Unpacking the Power Supply/Accessory Kit Crate (Cont'd)



- c) *Using two people, lift the cover up so that it clears the contents, then set it aside.*
- d) *Inspect the shock watches on each box. If they are tripped, call your Spectra-Physics representative immediately. If they are not tripped, proceed.*
- e) *Remove the two straps shown in Figure 4-5 and remove the two boxes from the pallet.*



## Unpacking the Power Supply

1. Open the large power supply box and remove the center foam piece.



2. Open the inner bag, then open the inner box and remove the white styrofoam piece.



3. When the inner box is opened, remove the accessory bags, and place them in a safe location. They are needed to connect the laser system.



## Unpacking the Power Supply (Cont'd)

4. Remove the accessory tray.



5. Use the handles to lift the cradle and power supply out of the inner box. Figure 4-10 shows the carrier being lifted out of the box.



6. Do a preliminary inspection of the power supply for damage and, if found, report the damage to Spectra-Physics. If there is no damage, proceed with the next step.
7. Place all the packing materials in the crate and reseal the crate.
8. Place the power supply and accessory kit on a cart for transfer to the installation site.

If it is necessary to ship the power supply, reverse this process.

## Unpacking the Laser Head

Remove to cover of the shipping crate containing the laser head.

- a) Using metal cutters, cut the shipping band.
- b) Unfasten the four clamps around the *bottom* of the crate that fasten the top portion of the crate (the cover) to the palette. Turn the handles counter-clockwise and disengage the latch as shown



- c) Undo the locks from the crate to the base



## Unpacking the Laser Head (Cont'd)

- d) 3. Unbuckle the straps holding the laser head in place.



- e) 4. Unscrew the clamps on the front and back of the laser head using a 1/2 in. driver.

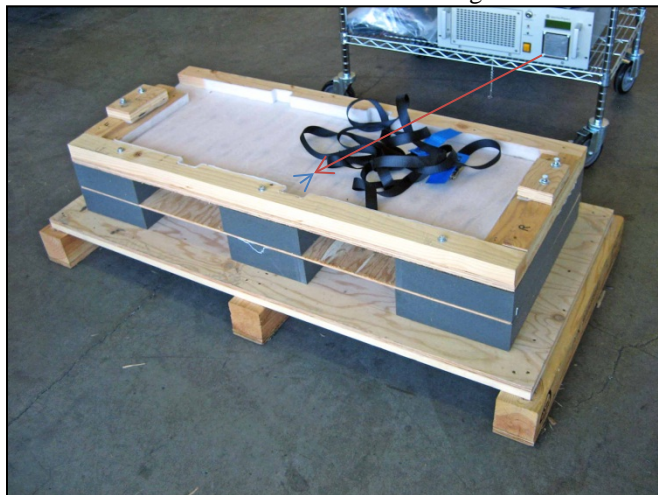

- f) Open all of the bags to expose the lifting eyelet. This is where the lifting mechanism attaches to the laser to remove it from the crate.



## Unpacking the Laser Head (Cont'd)

- g) A lift can be used to remove the laser head from the crate to a cart or table. Attach the lift to the eyelet.



- h) Alternatively, two handles are provided to assist in moving the laser. The hardware is already attached to the laser while inside the crate. Four people are required to move the laser.



- i) Place all packing material in the crate and close the crate.

## Unpacking the Optional Chiller

If the optional chiller is shipped with the system, open the chiller crate and remove the chiller.

- a) Using metal cutters, cut the shipping band.
- b) Unfasten the four clamps on the end of the crate (two on each side).



- c) Pull the top of the end cover down so that it lies down like a ramp.



- d) Remove the foam block and pull the chiller out of the crate and down the ramp.
- e) Remove the box of hoses and connectors and set it aside.
- f) Using **two people**, place the chiller, along with the hoses and connectors, on the cart with the power supply.
- g) Place all packing material in the crate and close the crate.

If the installation site is properly prepared, the *Quasar* is now ready for installation. Please refer to the *Quasar User's Manual* for Instructions.



## Packing the Laser System for Transportation or Return to Spectra-Physics

To return the *Quasar* system to Spectra-Physics for service, repair, or upgrade, use the original crates, boxes, bags, and packing material to repack it. Just reverse the unpacking instructions in the previous section to repack the system.

Before shipping the Laser Head you must make sure to purge the head for any residual water. This can be accomplished by using an external dry air source not to exceed 40 PSI. Attach the hoses to the inlet and outlet of the laser, place the outlet end of the hose into a bucket or sink, then place the air source into the inlet hose and blow all the water out of the laser head.

We encourage you to use the original crates and packing material to secure the instruments during shipment. If shipping crates, boxes, bags, or packing material have been lost or destroyed please contact your Spectra Physics Representative.

## Indexing and Multiple Mounting Schemes

The *Quasar* laser head is fastened to a mounting plate or mounting surface using three M6 or 1/4-20 bolts (Figure 5-1). Two of the mounting holes are located at the back of the laser and there is one mounting hole located at the front of the laser. The front mounting hole is offset to allow easy access to the mounting bolt when the optional shutter is installed.

Dowel pins can be used to index the laser into the same position. Using locating dowel pins eases laser replacement, since every unit is bore-sighted. This keeps systems realignment time to a minimum.

Align the laser head to the mounting surface, then drop the screws through the three mounting holes in the top of the laser head. Secure the laser head to the mounting surface using standard practice. When the laser is mounted the optional lifting handles can be removed for testing purposes. Once the laser is mounted into a tool or a permanent position the optional lifting handles and the exoskeleton can be removed.

**NOTE:** *Every system ships with the exoskeleton installed. We recommend that the exoskeleton remain attached to the laser.*

## Primary (Recommended) Installation Options for Bench Testing

Use three dowel pins (1/2" in diameter) for alignment of the position of the laser. One pin should be located on the front side of the laser. The two other pins should be located either along the left side of the laser (both of them) or along the right side of the laser (both of them). The pins are in contact with the laser base plate. It is recommended to secure the laser to the table with only one screw (either 1/4-20 or M6) which is located on the base plate in front of the laser housing.

## Additional Installation Options

If the customer is choosing to secure the laser with three screws, additional locations for the mounting screws are located at the rear corners of the base plate.

### Possible Minor Modification (can easily be implemented)

The tapped holes at the base of the plate can be used if the customer wants to attach the laser to the adaptor plate accessing it from the bottom through holes in the plate and screwing the bolts into the laser's shipping bracket plate.

It is possible to install an additional dowel pin at the back end of the laser and design a clamp that is screwed on to the customer's table. The clamp has the mating slot for the pin. There is a small gap (0.005" – 0.010") between the laser and the clamp in such a way that the clamp does not restrict the laser expansion but rather limits the motion due to external shock. For this option, the optional service handle at the back of the laser needs to be removed.

*See "Outline Drawings" for complete laser head and power supply dimensions.*

## Mounting Requirements for the Power Supply

The QPS is in a rack mountable enclosure. The following installation procedure assumes the power supply is installed into a standard 19-inch (48.3 cm) rackmount unit. Although such mounting is not required, this is the most compact mounting configuration when two or more laser systems are combined.

The power supply can be mounted using appropriate rackmount rails or set on a rackmount tray. Ensure that the rackmount unit is capable of supporting at least 16 kg (35 lb.). The front panel holes are only to be used to secure the power supply in the rack and are *not* meant to support the power supply itself. Three 10-32 screw holes are located along each side of the power supply to attach a rail or slide for rack mounting the unit.

*Provide at least 8 inches of room on the front and back of the QPS to allow cool and, preferably, clean air to enter the front panel and to exhaust from the rear panel. Inadequate cooling causes the unit to overheat and shut down. Damage caused by insufficient cooling is not covered by warranty.*

If the power supply is mounted in a rack, make sure it is appropriately ventilated. Take measures to prevent heated air exhausted from the back panels from returning to the cooling air intake on the front. Failure to do so causes overheating, which shuts off the power supply and can even damage it. When using a closed rack unit, provide positive filtered ventilation air that flows into the unit, then up past the mounted units without obstruction, and exhausts from the back. Do not add full shelves between units, or heated exhaust air is trapped and causes overheating.

Ensure that the electrical cables and interface cables are safely routed and are not under any strain. Avoid conditions where these cables can be stepped on by personnel.

## Installation Requirements for the Chiller

### General Information

Most laser systems generate a significant amount of heat that must be removed for proper operation. This laser is no different. This system requires a chiller that meets the requirements shown below.

<b>Feature</b>	<b>Requirement</b>
Flow rate	9.5 lpm (2.5 gpm) required
Coolant pressure	30 psi (210 kPa)
Coolant temperature	20°C (68°F)
Coolant temperature stability	>±0.5°C
Coolant type	Nalco 460-PCCL104 (recommended) or distilled water (4 Gallon Capacity, preferred mix is 2 Gallons of Nalco and 2 Gallons of distilled water.)

Spectra-Physics provides optional chillers that are suitable for use with the *Quasar* laser system. If your chiller was ordered from the factory with your laser, it meets these requirements. For specific information about the chiller shipped with your system, consult the chiller manual included with the system.

If your chiller was not ordered from Spectra-Physics, obtain a chiller that meets these requirements. Make sure that all wetted surfaces are either stainless steel, copper, nickel, Tygon, silicone, or Teflon. Also make sure that the coolant is filtered through a 5 micron, pleated, absolute particle size filter prior to entering the laser. Volumetric filters are NOT acceptable. We highly recommend that you speak with a Spectra-Physics representative about your chiller's design and capabilities.

## Interconnect Diagram

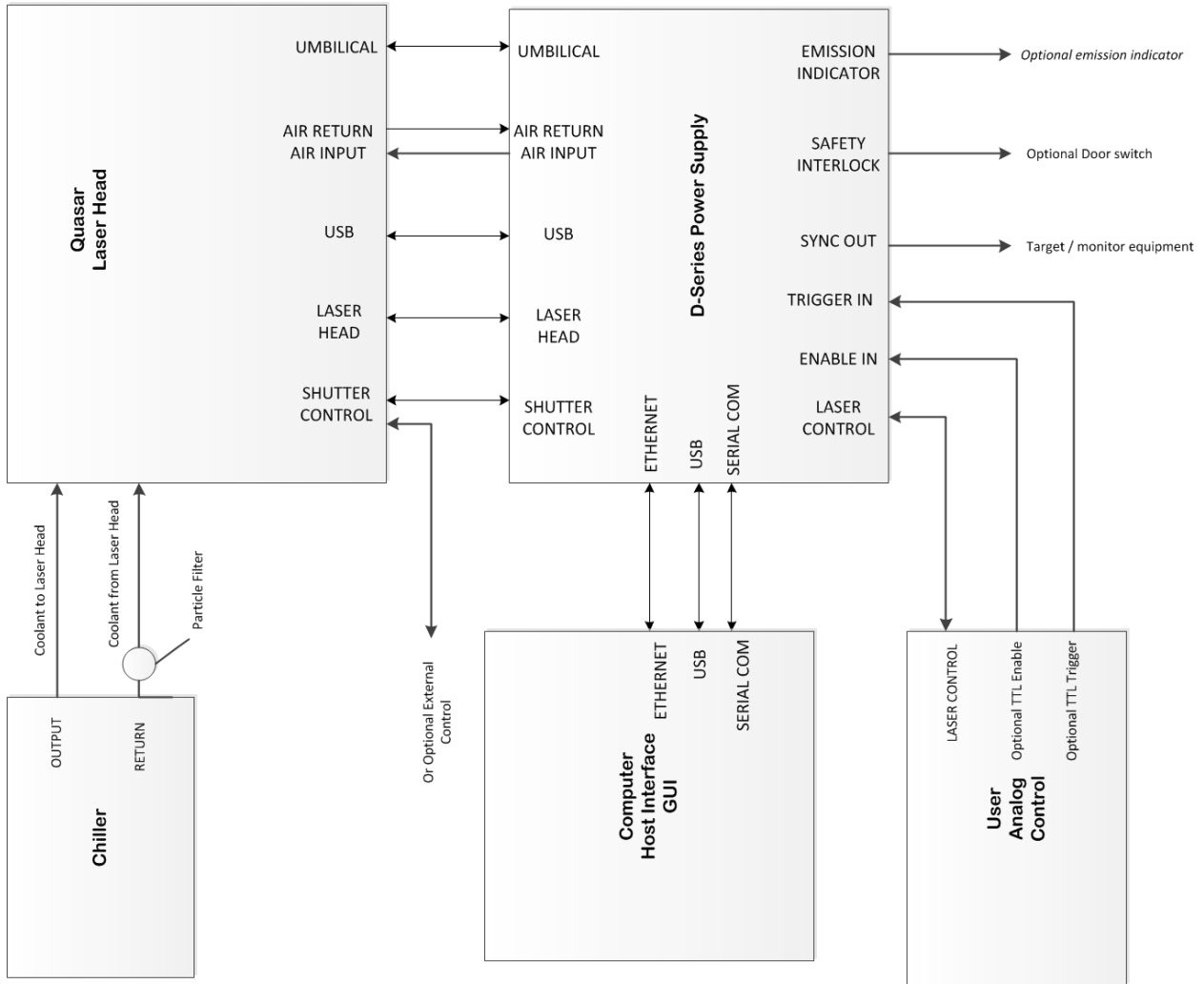

## Required Maintenance:

Power supply filters should be cleaned or replaced every 3 to 6 months.

Chiller should have its fluid changed every 6 months at a minimum. Check chiller hoses every 3 to 6 months.

Laser head desiccant should be replaced every 12 months.

ALPS (active laser purification system) should be replaced every 12 months.