

# Quasar®

## High Power UV and Green Hybrid Fiber Lasers for Fast Precision Micromachining

mks | Spectra-Physics®

The breakthrough performance of the Quasar series leads the industry with unprecedented highest UV average power and energy at high rep rate for fast micromachining. Quasar features novel TimeShift™ technology for programmable pulse profiles for the ultimate in process speed, flexibility, and control.

### Breakthrough Technology

Quasar combines advanced fiber laser, power amplifier and patented harmonics technologies to achieve breakthrough results. This unique design exploits fiber laser flexibility and robustness to enable TimeShift technology. Adding Spectra-Physics' exclusive power amplifier, Quasar enhances this flexibility at unprecedented high output power levels. Finally, with Spectra-Physics' patented harmonics, known for exceptional stability, Quasar continues to provide an innovative synergy of power, flexibility and control in a reliable 24/7 OEM laser for the most demanding applications.

### The Quasar Advantage

- >80 W UV (400 μJ) or >60 W UV (300 μJ)
- >95 W Green (475 μJ) or >75 W Green (375 μJ)
- TimeShift Technology
  - Constant pulse width over wide range of repetition rates
  - Variable pulse width
  - Pulse shaping
  - Pulse splitting and Burst mode operation
- High repetition rates from 0–3.5 MHz for fast processing
- Robust and reliable for OEM tools
- Datalog for critical performance monitoring and diagnostics

### Applications

- Glass cutting and drilling
- PCB drilling
- PCB cutting and dpaneling
- HDI (high density interconnects)
- Si crystallization
- Si wafer dicing
- Low K dielectric grooving
- Ceramic processing
- LED processing
- Solar cell processing
- ITO patterning
- Photolithography
- CFRP cutting and drilling
- Thin film planar battery cutting
- Drilling and scribing MDM polymers



# Quasar

## Breakthrough Performance

The Quasar UV80 produces >80 W of UV output power at specification point 200 kHz 10 ns and >400  $\mu$ J pulse energy, complementing Spectra-Physics' breakthrough Quasar UV45, UV60 and UV60-Turbo lasers. The Quasar UV80 operates over a wide repetition rate range from 0–3.5 MHz, with pulse widths from <2 ns to >100 ns. The Quasar UV60 produces >60 W of UV output power at specification point 300 kHz 10 ns. The Quasar UV60-Turbo, optimized for high repetition rate performance, produces >38 W of UV output power at specification point 3 MHz 2 ns. The Quasar UV60-Turbo is an excellent match for high speed polygon scanning systems. The Quasar GR95 produces >95 W of green output power, with similar pulse width and PRF range as the Quasar UV60, complementing Spectra-Physics' breakthrough Quasar UV45 laser.

Quasar is designed, built, and tested to stringent quality standards for reliable continuous operation in demanding 24/7 manufacturing environments. The built-in ALPS (Active Laser Purification System) helps sustain that performance for long life. And finally, Quasar lasers' automatic data logging software monitors all key laser performance parameters over the life of the laser, providing a powerful service feature and product reliability tool. A customer version of this software is also available.

Quasar UV80 Power vs  
Repetition Rate Performance<sup>1</sup>

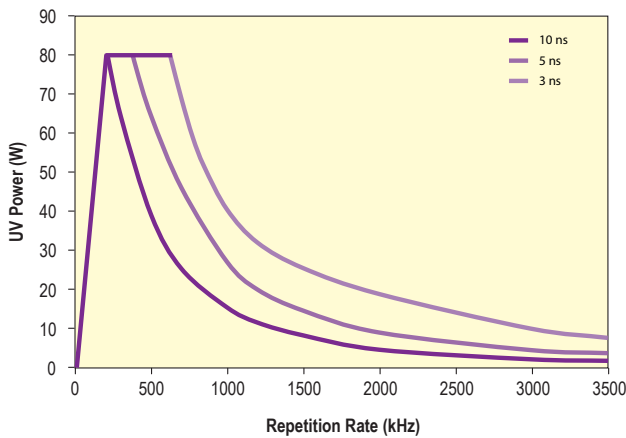

1. Quasar UV80 specified power is >80 W at 200 kHz 10 ns. Other points on graph are not a guaranteed or warranted specification.

Quasar UV60 Power vs  
Repetition Rate Performance<sup>1</sup>

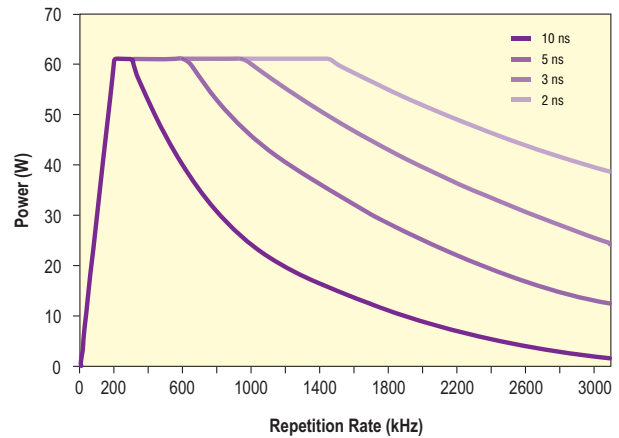

1. Quasar UV60 specified power is >60 W at 300 kHz 10 ns. Quasar UV60-Turbo specified power is >38 W at 3 MHz 2 ns. Other points on graph are not a guaranteed or warranted specification.

# Quasar

Quasar GR95 Power vs  
Repetition Rate Performance<sup>1</sup>

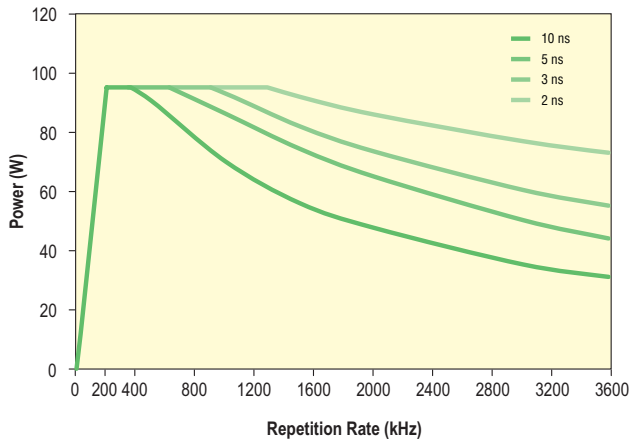

1. Quasar GR95 specified power is >95 W at 200 kHz 10 ns. Quasar GR75 specified power is >75 W at 200 kHz 10 ns. Other points on graph are not a guaranteed or warranted specification.

## TimeShift Technology – Expanding and/or Compressing (Controlling) Output in the Time Domain to Enhance Utilization

Quasar is the first laser of this class to offer TimeShift technology, which enables pulse energy programmability in the time domain. By controlling the laser pulse (width and shape) in time and repetition rate, material removal and/or modification in micromachining becomes more efficient, thereby increasing process speed and quality. Utilizing TimeShift in conjunction with high UV or green power at a higher repetition rate means Quasar can process more materials faster, and with greater quality. TimeShift enables pulse width variation, as well as pulse splitting and burst mode operation. For the Quasar UV80, UV60, UV60-Turbo and GR95 models, pulse widths from <2 ns to >100 ns can be created at a constant repetition rate or conversely, maintain constant pulse width with varying repetition rate from 0 to 3.5 MHz. A set of standard TimeShift waveforms is provided with each Quasar. The TimeShift GUI, which enables users to develop custom waveforms, is available at an additional cost.

# Quasar

## TimeShift Technology Flexibility and Benefits

### TimeShift Constant Pulse Width vs Pulse Repetition Frequencies (PRF)

Unlike conventional Q-switched lasers, Quasar's TimeShift technology can maintain constant pulse width over a wide range of repetition rates or pulse repetition frequencies (PRF). Constant pulse width means the peak power remains more constant, allowing for more consistent process results at higher speeds.

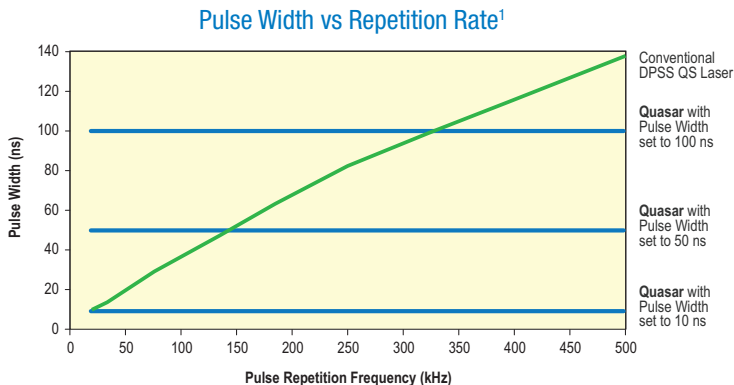

### Actual Pulse Traces of Constant Pulse Widths vs PRF

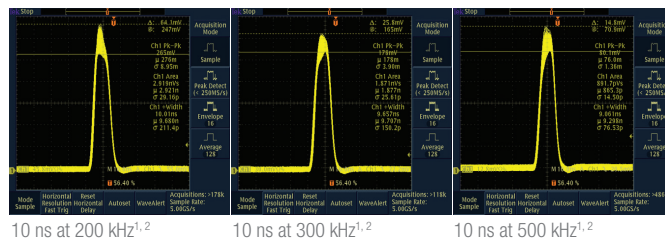

### TimeShift Variable Pulse Width and Pulse Shaping

Varying the pulse width for a given PRF can be used to optimize the material interaction. By changing the energy and intensity within a pulse (pulse shaping), the heating or cooling of the material is further optimized.

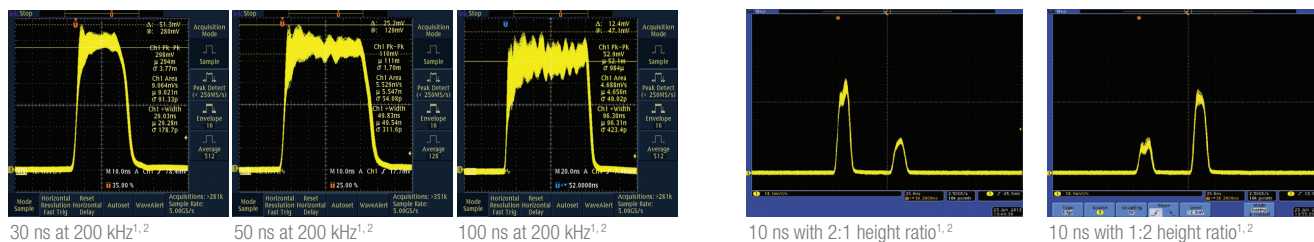

### TimeShift Pulse Splitting and Burst Mode

By splitting the pulses at a given PRF, the material is allowed to dissipate the heat or plasma such that more efficient material removal is possible. By altering the number, spacing, and relativity intensity of pulses within the burst, the spatial-temporal thermal profile in the work piece can be precisely tailored, increasing process speed and/or quality.

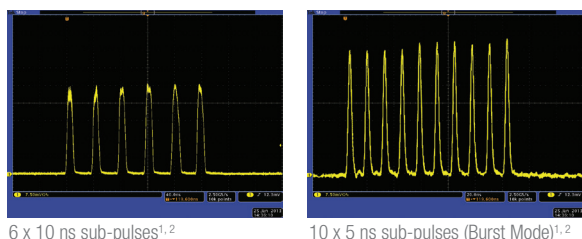

1. Typically measured performance; not a guaranteed or warranted specification.  
 2. Vertical range on oscilloscope set so that pulse peak is 75% of window.

# Quasar Specifications<sup>1, 2, 5</sup>

	Quasar UV80	Quasar UV60	Quasar UV60-Turbo	Quasar UV45
<b>Output Characteristics</b>				
Wavelength	355 nm	355 nm	355 nm	355 nm
Output Power	>80 W @ 200 kHz, 10 ns	>60 W @ 200 kHz, 10 ns >60 W @ 300 kHz, 10 ns	>38 W @ 3 MHz, 2 ns	>45 W @ 200 kHz, 10 ns >45 W @ 250 kHz, 10 ns >41 W @ 300 kHz, 10 ns
Maximum Pulse Energy or Burst Energy	>400 µJ (pulse)	>300 µJ (pulse)	>12 µJ (pulse)	>225 µJ (pulse)
Repetition Rate Range	0–3.5 MHz	0–3.5 MHz	0–3.5 MHz	0–1.7 MHz
Optimized TimeShift™ Setting (Nominal setup for beam optimization)	200 kHz, 10 ns	300 kHz, 10 ns	3 MHz, 2 ns	300 kHz, 10 ns
Pulse-to-Pulse Energy Stability	<5%, 1σ			
Power Stability (after warm-up)	<2%, 1σ, over 8 hours			
Beam Pointing Stability	<±25 µrad/°C			
Power Stability (Peak to Peak) (after warm-up)	±3% over 8 hours			
Polarization	100:1, vertical			
Spatial Mode	TEM <sub>00</sub> (M <sup>2</sup> <1.3)			
Beam Divergence, full angle	<0.3 mrad			
Beam Asymmetry	<1.10			
Pulse Width, FWHM (TimeShift programmable) <sup>3</sup>	<2 ns to >100 ns			<5 ns to >100 ns
Beam Diameter (D4σ)	3.5 ±0.35 mm			
Boresight Tolerance	±0.5 mm ±5 mrad			
<b>Operating Conditions</b>				
Warm-up Time, typical	<40 min Electrical ON, Diodes OFF; <60 min from Electrical OFF, Diodes OFF			
Temperature Range	15–35°C			
Altitude	0–2000 m			
Humidity	10–80% non-condensing			
<b>Storage Conditions</b>				
Temperature Range	0–50°C			
Altitude	0–10,000 m			
Humidity	10–80% non-condensing			
<b>Electrical and Chiller Requirements</b>				
Heat Load (at laser head)	<1900 W	<1500 W		
Water Temperature (laser inlet)	20°C ±1°C			
Water Flow Rate (at laser head)	≥9.5 l/min			
Power Input	190–240 VAC, 2500 W maximum, 50/60 Hz, single phase			
Heat Load (at power supply)	<500 W	<400 W		
Power Consumption	<2400 W	<2000 W		
Water Temperature Stability	±0.5°C			
<b>Physical Characteristics</b>				
Laser Head Dimensions (L x W x H) <sup>4</sup>	39.4 x 14.7 x 9.3 in (1000 x 373 x 235 mm)			
Laser Head Weight	200 lbs (90 kg)			
Power Supply Dimensions (L x W x H)	21.1 x 19.0 x 6.9 in (536 x 483 x 176 mm)			
Power Supply Weight	35 lbs (16 kg)			
Cable Length	5 m			
<b>Other</b>				
Complies with EU Directive 2015/863/EU; China RoHS2 GB/T 26572---2011 and SJ/T 11364---2014	Yes			
User Replaceable Output Window	Yes			
Optional Safety Shutter	Yes			
Data Log (includes customer version as well)	Long and short term recording for diagnostics and equipment maintenance			

1. Due to our continuous product improvement program, specifications may change without notice.

2. Quasar UV80 nm test specs are at 10 ns at 200 kHz with the diode current set to achieve 81 W. Quasar UV60 and UV45 nm test specs are at 10 ns at 300 kHz with the diode current set to achieve 62 W for the Quasar UV60, and 42 W for the UV45. Quasar UV60-Turbo test specs are at 3 MHz 2 ns with diode current set to achieve 40 W.

3. Quasar UV80, UV60 and UV45: nominal pulse width 10 ns. Quasar UV60-Turbo nominal and pulse width is 2 ns. Alternative/programmable pulse widths using TimeShift will change power and beam parameter performance. Contact Spectra-Physics for more information.

4. Quasar UV80, UV60, UV60-Turbo and UV45 dimensions noted do not include the standard removable lifting hoist exoskeleton or the optionally removable lift handles.

5. Quasar is a Class IV - High Power Laser, whose beam is, by definition, a safety and fire hazard. Take precautions to prevent exposure to the direct and reflected beams. Diffuse as well as specular reflections can cause severe skin or eye damage.

# Quasar Specifications<sup>1, 2, 5</sup>

	Quasar GR95	Quasar GR75
<b>Output Characteristics</b>		
Wavelength	532 nm	532 nm
Output Power	>95W @ 200 kHz, 10 ns	>75W @ 200 kHz, 10 ns
Maximum Pulse Energy or Burst Energy	>475 $\mu$ J	>375 $\mu$ J
Repetition Rate Range	0–3.5 MHz	0–1.7 MHz
Optimized TimeShift™ Setting (Nominal setup for beam optimization)	200 kHz, 10 ns	
Pulse-to-Pulse Energy Stability	<5%, 1 $\sigma$	
Power Stability (after warm-up)	<2%, 1 $\sigma$ , over 8 hours	
Beam Pointing Stability	< $\pm$ 25 $\mu$ rad/°C	
Power Stability (Peak to Peak) (after warm-up)	$\pm$ 3% over 8 hours	
Polarization	100:1, horizontal	
Spatial Mode	TEM <sub>00</sub> (M <sup>2</sup> <1.3)	
Beam Divergence, full angle	< 0.45 mrad	
Beam Asymmetry	<1.10	
Pulse Width, FWHM (TimeShift programmable) <sup>3</sup>	<2 ns to >100 ns	<5 ns to >100 ns
Beam Diameter (D4 $\sigma$ )	3.5 $\pm$ 0.35 mm	
Boresight Tolerance	$\pm$ 0.5 mm $\pm$ 5 mrad	
<b>Operating Conditions</b>		
Warm-up Time, typical	<40 min Electrical ON, Diodes OFF; <60 min from Electrical OFF, Diodes OFF	
Temperature Range	15–35°C	
Altitude	0–2000 m	
Humidity	10–80% non-condensing	
<b>Storage Conditions</b>		
Temperature Range	0–50°C	
Altitude	0–10,000 m	
Humidity	10–80% non-condensing	
<b>Electrical and Chiller Requirements</b>		
Heat Load (at laser head)	<1500 W	
Water Temperature (laser inlet)	20°C $\pm$ 1°C	
Water Flow Rate (at laser head)	9.5 l/min	
Power Input	190–240 VAC, 2500 W maximum, 50/60 Hz, single phase	
Heat Load (at power supply)	<400 W	
Power Consumption	<2000 W	
Water Temperature Stability	$\pm$ 0.5°C	
<b>Physical Characteristics</b>		
Laser Head Dimensions (L x W x H) <sup>4</sup>	39.4 x 14.7 x 9.3 in (1000 x 373 x 235 mm)	
Laser Head Weight	200 lbs (90 kg)	
Power Supply Dimensions (L x W x H)	21.1 x 19.0 x 6.9 in (536 x 483 x 176 mm)	
Power Supply Weight	35 lbs (16 kg)	
Cable Length	5 m	
<b>Other</b>		
Complies with EU Directive 2015/863/EU; China RoHS2 GB/T 26572---2011 and SJ/T 11364---2014	Yes	
User Replaceable Output Window	Yes	
Optional Safety Shutter	Yes	
Data Log (includes customer version as well)	Long and short term recording for diagnostics and equipment maintenance	

1. Due to our continuous product improvement program, specifications may change without notice.

2. All green wavelength test specs are at 10 ns at 200 kHz with the diode current set to achieve 97 Watts for the Quasar GR95 and 77 Watts for the GR75.

3. Quasar GR95 and GR75: nominal pulse width is 10 ns.

4. Quasar GR95 and GR75 dimensions noted do not include the standard removable lifting hoist exoskeleton or the optionally removable lift handles.

5. Quasar is a Class IV - High Power Laser, whose beam is, by definition, a safety and fire hazard. Take precautions to prevent exposure to the direct and reflected beams. Diffuse as well as specular reflections can cause severe skin or eye damage.

# Quasar

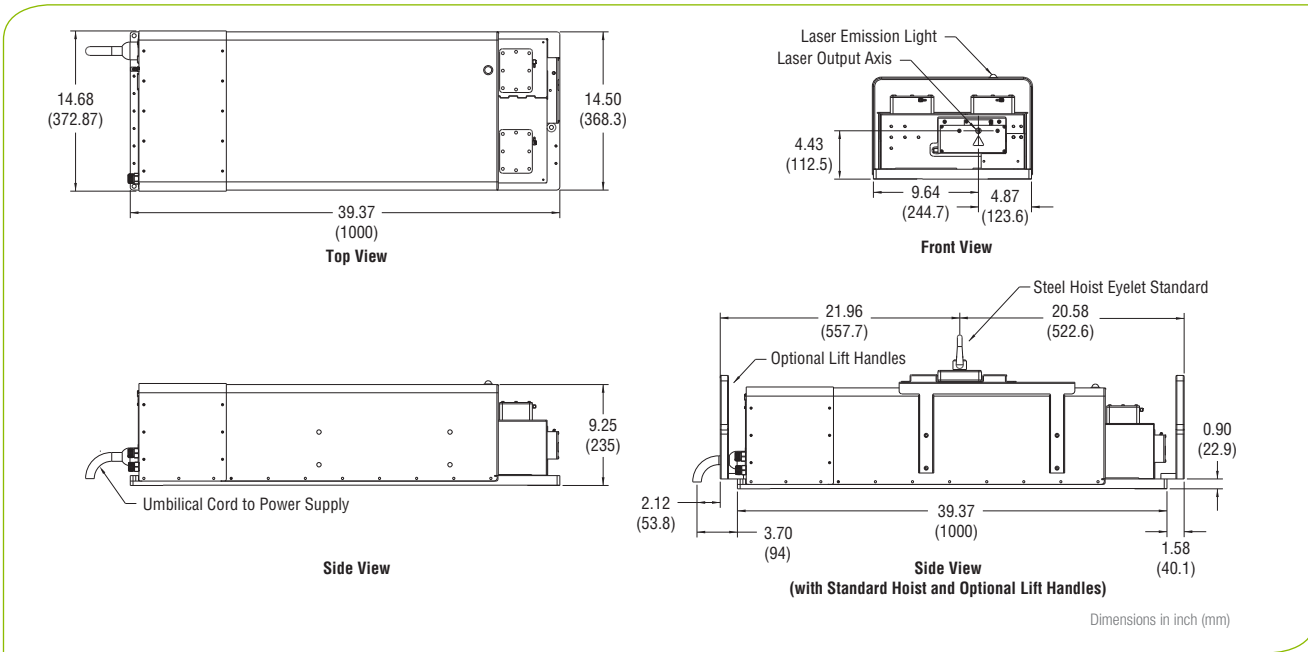

Quasar Laser Head Dimensions

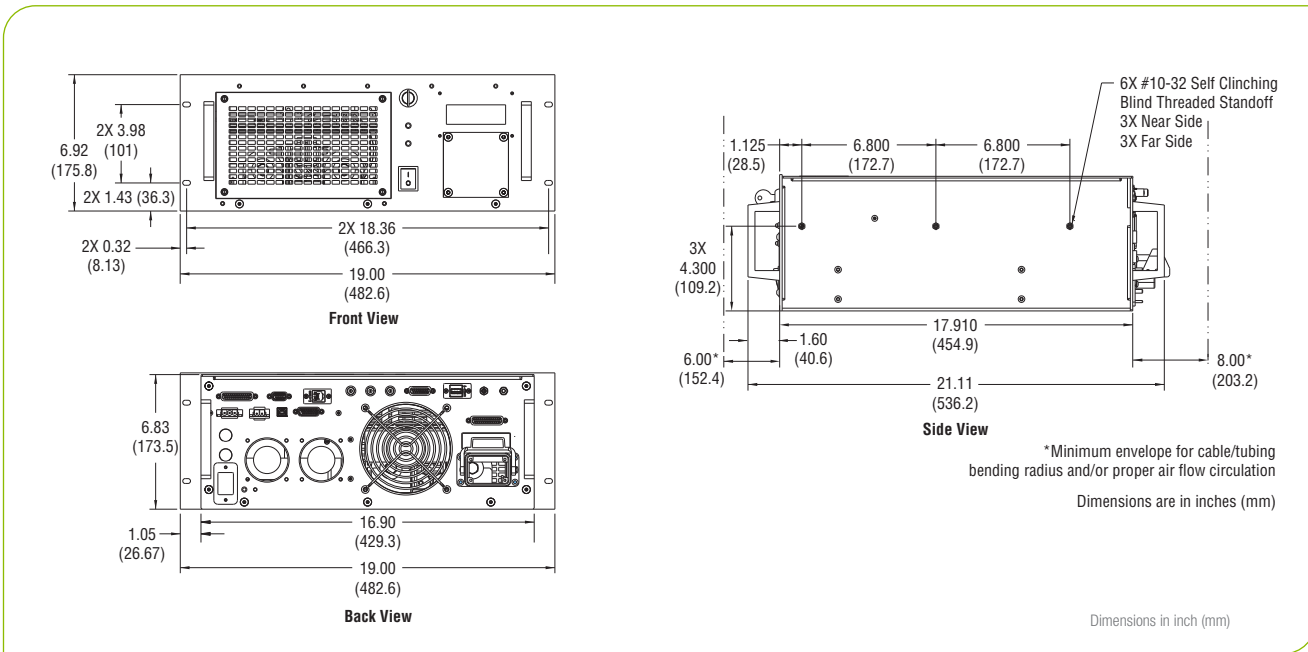

Quasar Power Supply Dimensions



www.spectra-physics.com

1565 Barber Lane, Milpitas, CA 95035 USA  
 PHONE: 1-800-775-5273 1-408-980-4300 FAX: 1-408-980-6921 EMAIL: sales@spectra-physics.com

Belgium	+32-(0)800-11 257	belgium@newport.com	Korea	+82-31-8021-1600	korea@spectra-physics.com
China	+86-10-6267-0065	info@spectra-physics.com.cn	Netherlands	+31-(0)30 6592111	netherlands@newport.com
France	+33-(0)1-60-91-68-68	france@newport.com	Singapore	+65-6664-0040	sales.sg@newport.com
Germany / Austria / Switzerland	+49-(0)6151-708-0	germany@newport.com	Taiwan	+886-3-575-3040	sales@newport.com.tw
Japan	+81-3-3556-2705	spectra-physics.jp@mksinst.com	United Kingdom	+44-1235-432-710	uk@newport.com